

OSLON Black Series (940 nm)
Lead (Pb) Free Product - RoHS Compliant

SFH 4725S

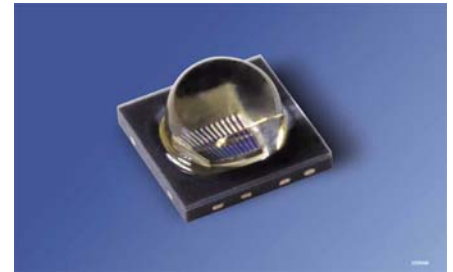

DRAFT - This design is for Reference only.

Subject to change without notice.

Wesentliche Merkmale

- IR-Lichtquelle mit hohem Wirkungsgrad
- niedriger Wärmewiderstand (Max. 11 K/W)
- Schwerpunktwellenlänge 940 nm
- ESD-sicher bis 2 kV nach JESD22-A114-E
- Erweiterte Korrosionsfestigkeit
(s.a. Abschnitt Maßzeichnung)

Anwendungen

- Infrarotbeleuchtung für Kameras
- Überwachungssysteme
- Beleuchtung für Bilderkennungssysteme

Sicherheitshinweise

Je nach Betriebsart emittieren diese Bauteile hochkonzentrierte, nicht sichtbare Infrarot-Strahlung, die gefährlich für das menschliche Auge sein kann. Produkte, die diese Bauteile enthalten, müssen gemäß den Sicherheitsrichtlinien der IEC-Normen 60825-1 und 62471 behandelt werden.

Features

- IR lightsource with high efficiency
- Low thermal resistance (Max. 11 K/W)
- Center of spectral emission at 940 nm
- ESD safe up to 2 kV acc. to JESD22-A114-E
- Superior Corrosion Robustness
(see chapter package outlines)

Applications

- Infrared Illumination for cameras
- Surveillance systems
- Machine vision systems

Safety Advices

Depending on the mode of operation, these devices emit highly concentrated non visible infrared light which can be hazardous to the human eye. Products which incorporate these devices have to follow the safety precautions given in IEC 60825-1 and IEC 62471.

Typ Type	Bestellnummer Ordering Code	Strahlstärkegruppierung ¹⁾ ($I_F = 1 \text{ A}$, $t_p = 10 \text{ ms}$) Radiant Intensity Grouping ¹⁾ I_e (mW/sr)
SFH 4725S	on request	≥ 320 (typ. 450)

¹⁾ gemessen bei einem Raumwinkel $\Omega = 0.01 \text{ sr}$ / measured at a solid angle of $\Omega = 0.01 \text{ sr}$

Grenzwerte ($T_A = 25\text{ °C}$)**Maximum Ratings**

Bezeichnung Parameter	Symbol Symbol	Wert Value	Einheit Unit
Betriebs- und Lagertemperatur Operating and storage temperature range	T_{op}, T_{stg}	- 40 ... + 125	°C
Sperrschichttemperatur Junction temperature	T_J	+ 145	°C
Sperrspannung Reverse voltage	V_R	1	V
Vorwärtsgleichstrom Forward current	I_F	1	A
Stoßstrom, $t_p = 500\text{ }\mu\text{s}$, $D = 0$ Surge current	I_{FSM}	5	A
Leistungsaufnahme Power consumption	P_{tot}	3.4	W
Wärmewiderstand Sperrschicht - Lötstelle Thermal resistance junction - soldering point	R_{thJS}	11	K/W

Kennwerte ($T_A = 25\text{ °C}$)**Characteristics**

Bezeichnung Parameter	Symbol Symbol	Wert Value	Einheit Unit
Wellenlänge der Strahlung Wavelength at peak emission $I_F = 1\text{ A}$, $t_p = 10\text{ ms}$	λ_{peak}	950	nm
Centroid-Wellenlänge der Strahlung Centroid wavelength $I_F = 1\text{ A}$, $t_p = 10\text{ ms}$	$\lambda_{centroid}$	940	nm
Spektrale Bandbreite bei 50% von I_{max} Spectral bandwidth at 50% of I_{max} $I_F = 1\text{ A}$, $t_p = 10\text{ ms}$	$\Delta\lambda$	37	nm
Abstrahlwinkel Half angle	φ	± 45	Grad deg.
Abmessungen der aktiven Chipfläche Dimension of the active chip area	$L \times B$ $L \times W$	1×1	mm ²
Schaltzeiten, I_e von 10% auf 90% und von 90% auf 10%, $I_F = 5\text{ A}$, $R_L = 50\text{ }\Omega$ Switching times, I_e from 10% to 90% and from 90% to 10%, $I_F = 5\text{ A}$, $R_L = 50\text{ }\Omega$	t_r / t_f	tbd	ns

Kennwerte ($T_A = 25\text{ °C}$)
Characteristics (cont'd)

Bezeichnung Parameter	Symbol Symbol	Wert Value	Einheit Unit
Durchlassspannung Forward voltage $I_F = 1\text{ A}$, $t_p = 100\text{ }\mu\text{s}$ $I_F = 5\text{ A}$, $t_p = 100\text{ }\mu\text{s}$	V_F V_F	2.8 (< 3.4) 3.5 (< 4.5)	V V
Gesamtstrahlungsfluss Total radiant flux $I_F = 1\text{ A}$, $t_p = 100\text{ }\mu\text{s}$	Φ_e	935	mW
Temperaturkoeffizient von I_e bzw. Φ_e Temperature coefficient of I_e or Φ_e $I_F = 1\text{ A}$, $t_p = 10\text{ ms}$	TC_I	- 0.3	%/K
Temperaturkoeffizient von V_F Temperature coefficient of V_F $I_F = 1\text{ A}$, $t_p = 10\text{ ms}$	TC_V	- 4	mV/K
Temperaturkoeffizient von λ Temperature coefficient of λ $I_F = 1\text{ A}$, $t_p = 10\text{ ms}$	$TC_{\lambda,\text{centroid}}$	+ 0.3	nm/K

Strahlstärke I_e in Achsrichtung¹⁾gemessen bei einem Raumwinkel $\Omega = 0.01$ sr**Radiant Intensity I_e in Axial Direction**at a solid angle of $\Omega = 0.01$ sr

Bezeichnung Parameter	Symbol	Werte Values			Einheit Unit
		-CB	-DA	-DB	
Strahlstärke	$I_{e \text{ min}}$	320	400	500	mW/sr
Radiant intensity	$I_{e \text{ max}}$	500	630	800	mW/sr
$I_F = 1$ A, $t_p = 10$ ms					

- ¹⁾ Nur eine Gruppe in einer Verpackungseinheit (Streuung kleiner 1.6:1) /
Only one group in one packing unit (variation lower 1.6:1)

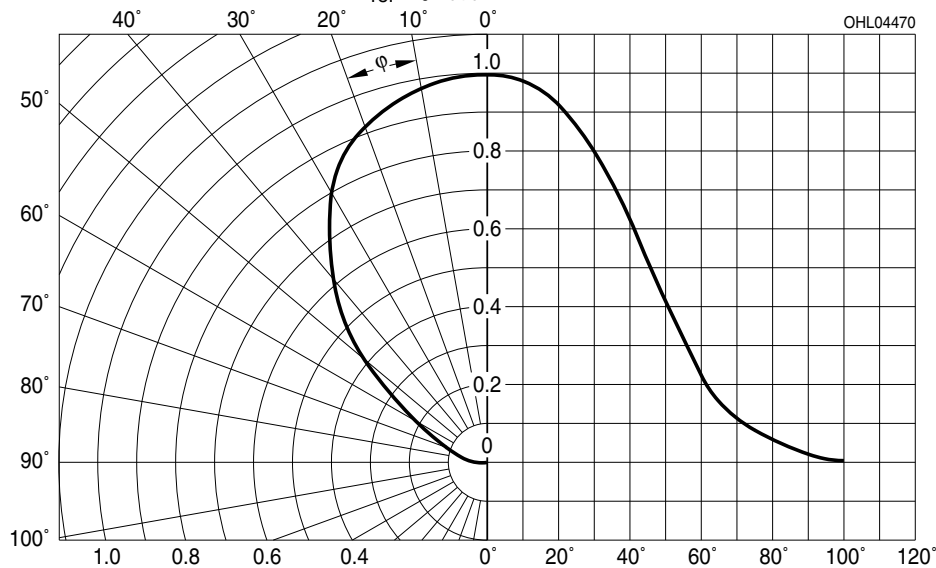
Abstrahlcharakteristik**Radiation Characteristics $I_{\text{rel}} = f(\varphi)$** 

Relative spektrale Emission
Relative Spectral Emission

$I_{rel} = f(\lambda)$

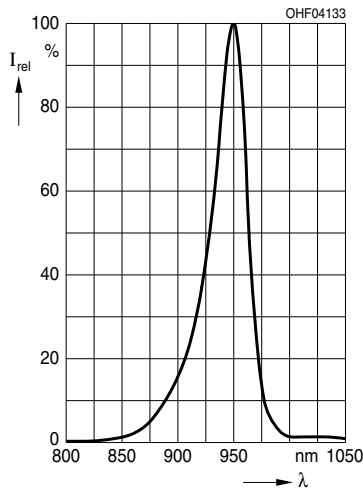

Durchlassstrom
Forward Current

$I_F = f(V_F)$

Single pulse, $t_p = 100 \mu s$

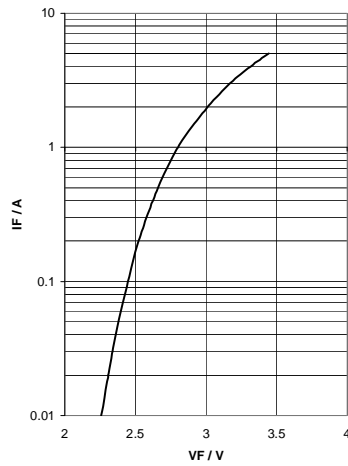

Relativer Gesamtstrahlungsfluss
Relative Total Radiant Flux

$\Phi_e / \Phi_e(1A) = f(I_F)$

Single pulse, $t_p = 100 \mu s$

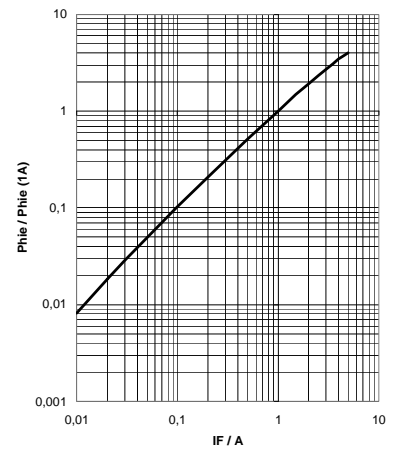

Max. zulässiger Durchlassstrom
Max. Permissible Forward Current

$I_F = f(T_A), R_{thJS} = 11 \text{ K/W}$

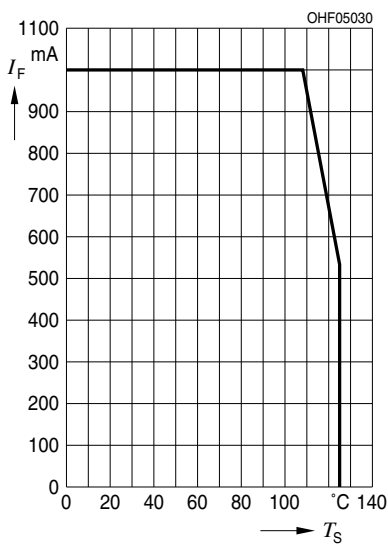

Zulässige Impulsbelastbarkeit
Permissible Pulse Handling

Capability $I_F = f(t_p), T_S = 85 \text{ }^\circ\text{C}$,
Duty cycle $D = \text{parameter}$

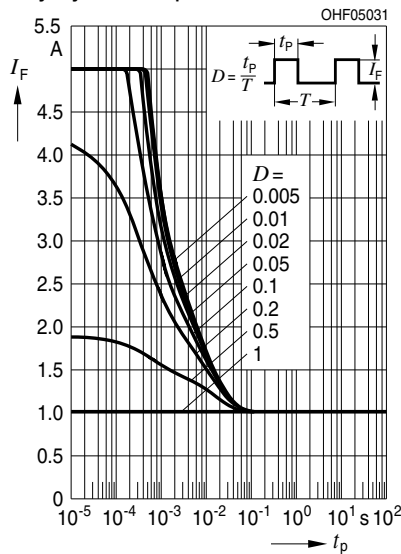

Maßzeichnung¹⁾
Package Outlines

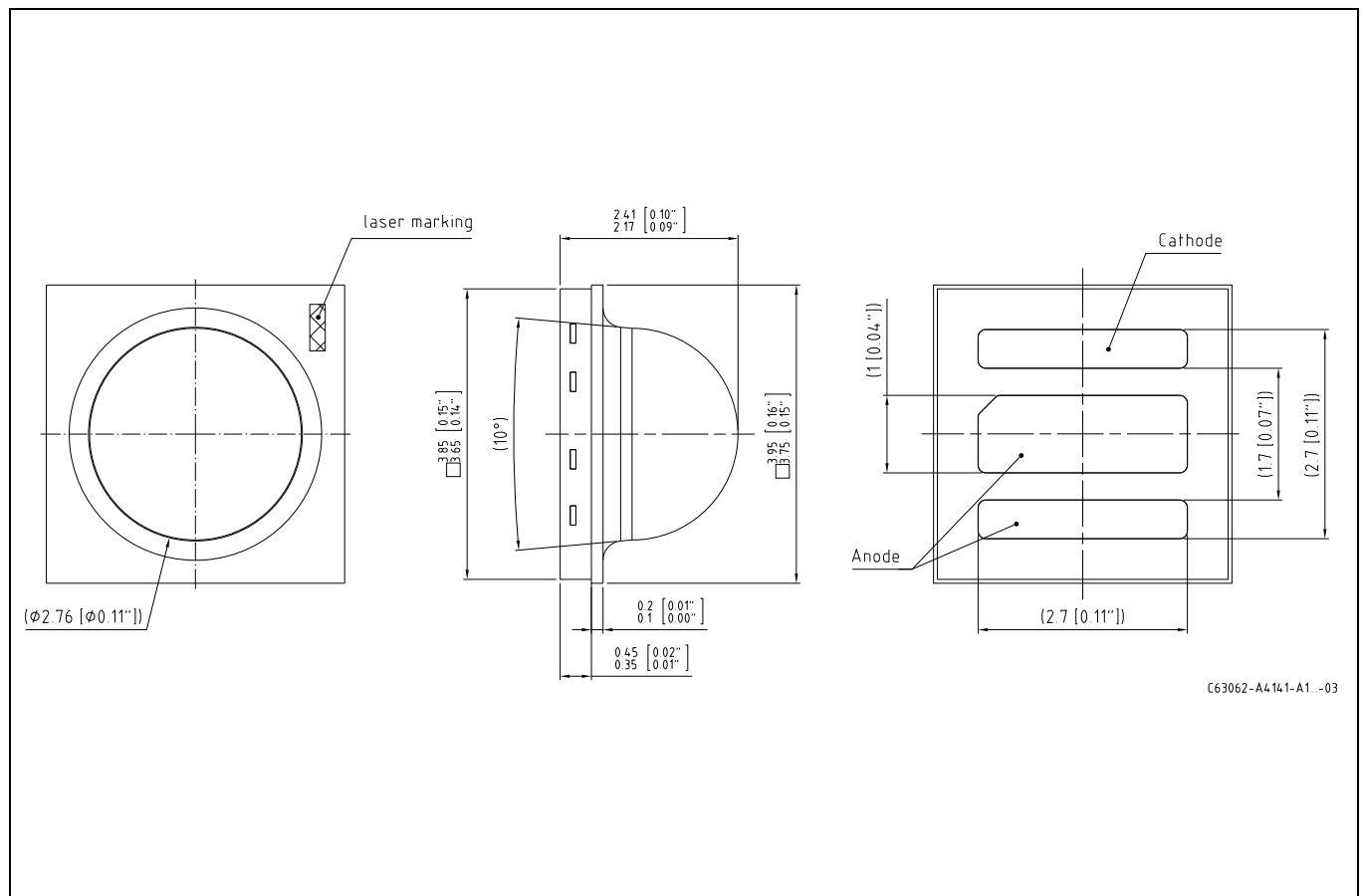

Note: Die IRED enthält ein ESD-Schutzbauteil, das parallel zum Chip geschaltet ist. / IRED is protected by ESD device which is connected in parallel to chip.

Note: Das Gehäuse ist für Ultraschallreinigung nicht geeignet. / Package is not suitable for ultra sonic cleaning.

Korrosionsfestigkeit besser als EN 60068-2-60 (method 4):
mit erweitertem Korrosionstest: 40°C / 90%rh / 15ppm H₂S / 336h

Corrosion robustness better than EN 60068-2-60 (method 4):
with enhanced corrosion test: 40°C / 90%rh / 15ppm H₂S / 336h

Anodenkennung: Anodenpad ist abgeschrägt und weist zur Kathode
Anode mark: Anode pad has chamfered edge, which points to cathode
Gewicht / Approx. weight: 32 mg

¹⁾ Maße in mm (inch) / Dimensions in mm (inch)

Gurtung / Polarität und Lage¹⁾
Method of Taping / Polarity and Orientation

Verpackungseinheit 600/Rolle, ø180 mm
 Packing unit 600/reel, ø180 mm

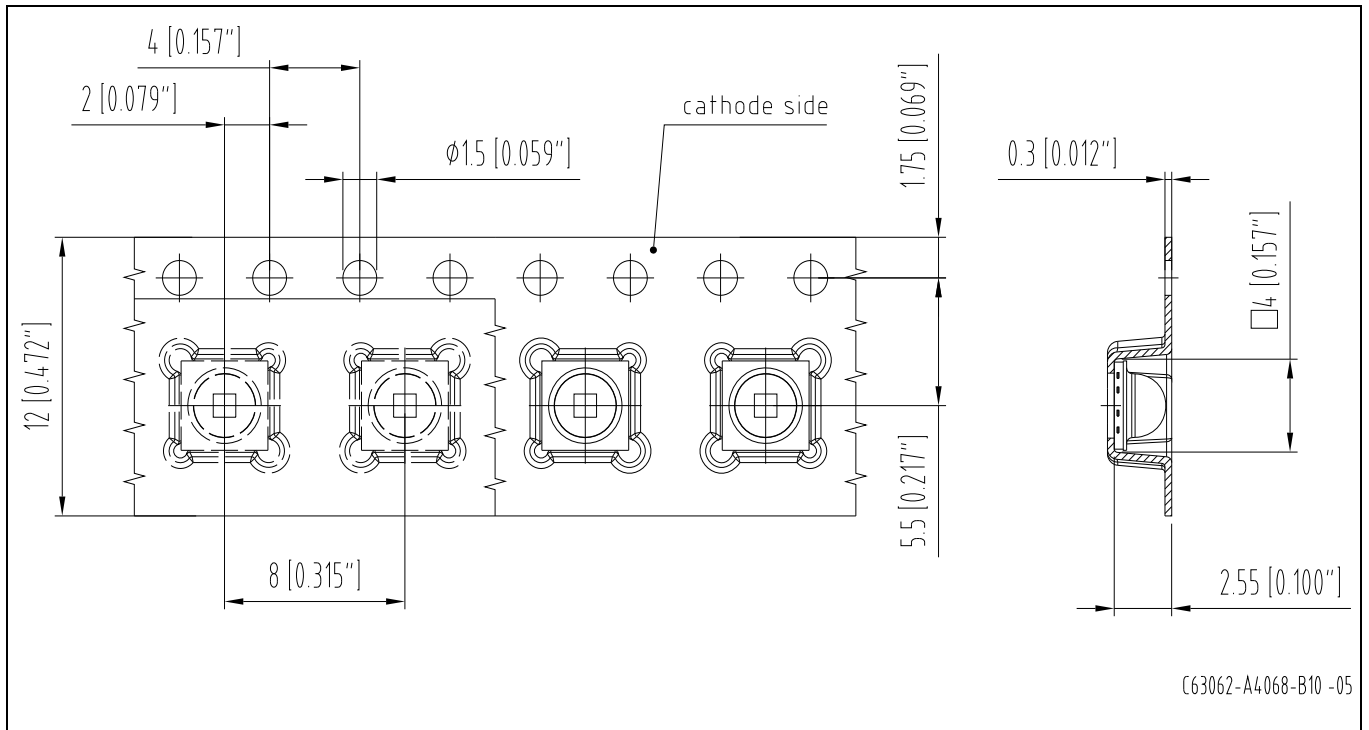

¹⁾ Maße in mm (inch) / Dimensions in mm (inch)

Empfohlenes Lötpaddesign¹⁾
Recommended Solder Pad Design

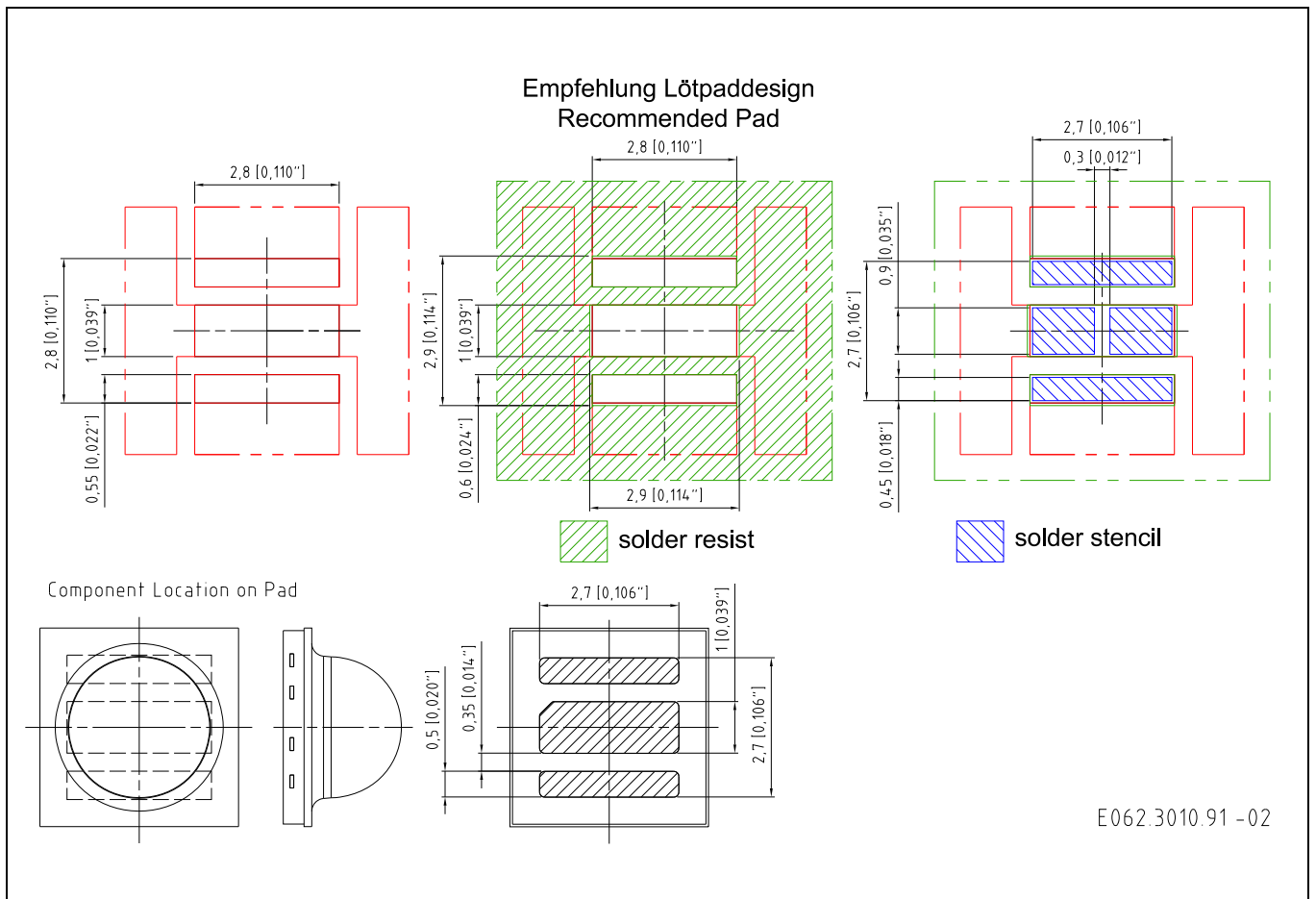

¹⁾ Maße in mm (inch) / Dimensions in mm (inch)

Lötbedingungen
Soldering Conditions

Reflow Lötprofil für bleifreies Löten
Reflow Soldering Profile for lead free soldering

Vorbehandlung nach JEDEC Level 2
Preconditioning acc. to JEDEC Level 2
(nach J-STD-020D.01)
(acc. to J-STD-020D.01)

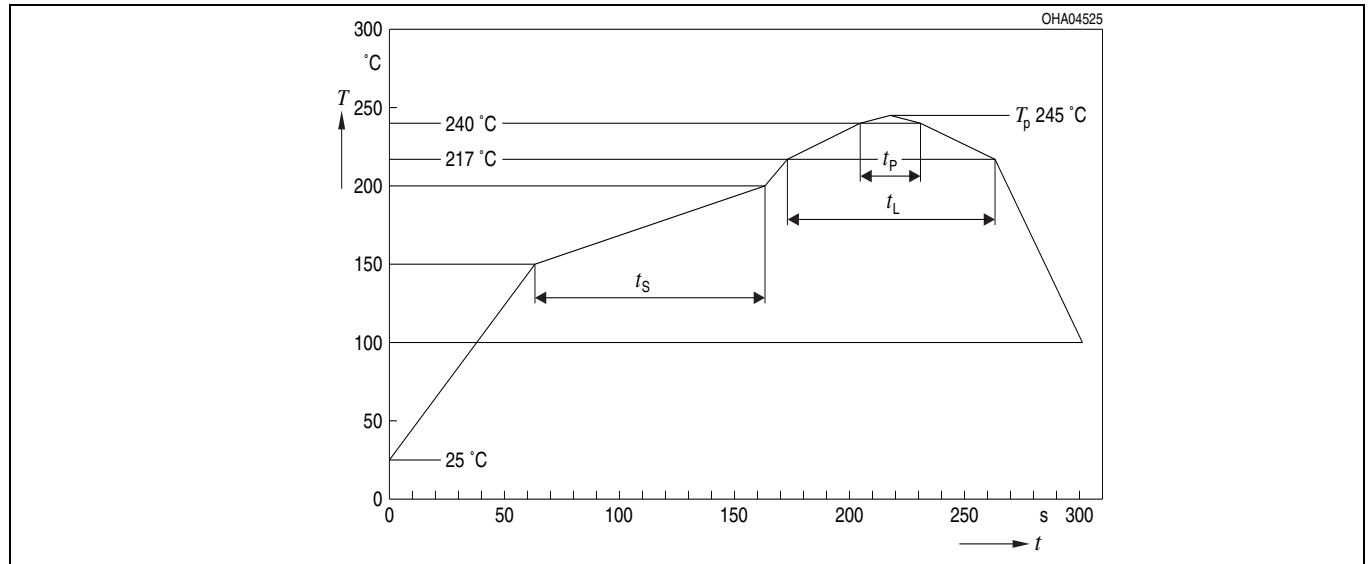

Profileigenschaften Profile Feature	Bleifreier Aufbau / Pb-Free Assembly (SnAgCu)	
	Empfehlung / Recommendation	Grenzwerte / Max. Ratings
Aufheizrate zum Vorwärmen*) / Ramp-up rate to preheat*) 25 °C to 150 °C	2 K / s	3 K / s
Zeit t _s von T _{Smin} bis T _{Smax} / Time t _s from T _{Smin} to T _{Smax} 150 °C to 200 °C	100 s	min. 60 s max. 120 s
Aufheizrate zur Spitztemperatur*) / Ramp-up rate to peak*) 180 °C to T _p	2 K / s	3 K / s
Liquidustemperatur T _L / Liquidus temperature T _L	217 °C	
Zeit t _L über T _L / Time t _L above T _L	80 s	max. 100 s
Spitztemperatur T _p / Peak temperature T _p	245 °C	max. 260 °C
Verweilzeit t _p innerhalb des spezifizierten Spitztemperaturbereichs T _p - 5 K / Time t _p within the specified peak temperature range T _p - 5 K	20 s	min. 10 s max. 30 s
Abkühlrate*) / Ramp-down rate*) T _p to 100 °C	3 K / s	6 K / s maximum
Zeitspanne von 25 °C bis zur Spitztemperatur / Time from 25 °C to peak temperature		max. 8 min.

Alle Temperaturen beziehen sich auf die Bauteilmitte, jeweils auf der Bauteiloberseite gemessen / All temperatures refer to the center of the package, measured on the top of the package

* Steigungsberechnung $\Delta T/\Delta t$: Δt max. 5 s; erfüllt über den gesamten Temperaturbereich / slope calculation $\Delta T/\Delta t$: Δt max. 5 s; fulfillment for the whole T-range

Published by
OSRAM Opto Semiconductors GmbH
Leibnizstraße 4, D-93055 Regensburg
www.osram-os.com
© All Rights Reserved.

EU RoHS and China RoHS compliant product



此产品符合欧盟 RoHS 指令的要求；
按照中国的相关法规和标准，不含有毒有害物质或元素。

The information describes the type of component and shall not be considered as assured characteristics. Terms of delivery and rights to change design reserved. Due to technical requirements components may contain dangerous substances. For information on the types in question please contact our Sales Organization.

Packing

Please use the recycling operators known to you. We can also help you – get in touch with your nearest sales office. By agreement we will take packing material back, if it is sorted. You must bear the costs of transport. For packing material that is returned to us unsorted or which we are not obliged to accept, we shall have to invoice you for any costs incurred.

Components used in life-support devices or systems must be expressly authorized for such purpose! Critical components ¹, may only be used in life-support devices or systems ² with the express written approval of OSRAM OS.

¹ A critical component is a component used in a life-support device or system whose failure can reasonably be expected to cause the failure of that life-support device or system, or to affect its safety or effectiveness of that device or system.

² Life support devices or systems are intended (a) to be implanted in the human body, or (b) to support and/or maintain and sustain human life. If they fail, it is reasonable to assume that the health of the user may be endangered.

Disclaimer

OSRAM OS assumes no liability whatsoever for any use of this document or its content by recipient including, but not limited to, for any design-in activities based on this preliminary draft version.